

INSTALLATION GUIDE

INTEGRATED INFOTAINMENT TOUCH SCREEN SOLUTION FOR
Audi R8 2007-2015

PART NUMBER: UN1810E-AU1



ABOUT THIS PRODUCT

Upgrade your Audi R8's radio with the HEIGH10® 10-inch infotainment system. Retain all OEM features, vehicle settings, and more. All in one easy to install, plug-and-play package.

The HEIGH10® is designed to enhance screen size and infotainment features for drivers which include Apple CarPlay, Android Auto, DAB+, and Bluetooth streaming. Paired with the vehicle retention interface, key vehicle settings will be retained and controlled through the HEIGH10® display by your steering wheel controls.

The components of this kit are compatible for the Audi R8 2007-2015, with bose-amplified Quadlock factory head units.

Please note: Not compatible for models with a digital amplifier. B&O audio equipment is not supported.



CONTENTS

- HEIGH10® unit with fitting accessories and wiring
- Black double DIN fascia plate (with accessories)
- Vehicle retention interface with plug-and-play harness
- Vehicle specific antenna adapter (AM/FM)
- Stinger stereo patch lead
- Instruction manual

FITTING GUIDE

STEREO REMOVAL



Step 1 -
Using 4x European release keys, insert a key into into each locating slot which can be found on the corners of the radio as indicated by the image. This will release the locking tabs securing the radio to the dash of the vehicle.



Step 2 -
Once the locking tabs have been released, gently pull forward the radio and disconnect the connections on the rear.



Step 3 -
Remove 2x T20 screws which can be found in the bottom corners of outer fascia housing. Using a plastic trim tool, careful pry the surrounding edges in order to free the housing from the dash.

FITTING GUIDE

STEREO REMOVAL



Step 4 -
Unplug the connector in order to free the outer fascia. This will be re installed once the new fascia is installed.

Take the HEIGH10® components and begin to assemble the core components in accordance with the “*Installation Manual*” that comes with unit.

HEIGH10 ASSEMBLY

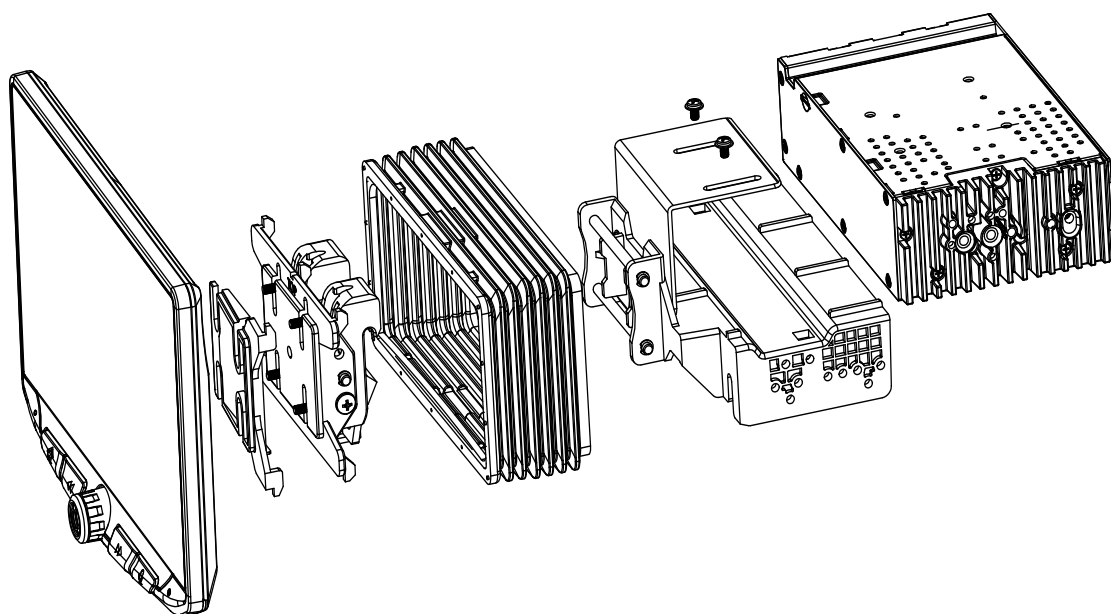

FITTING GUIDE

FASCIA PLATE SET-UP

1. With the HEIGH10® unit configured correctly, attach the fascia brackets to the relevant sides of the radio module using the screws within the kit. Place into the vehicle and roughly test fit with the fascia to measure whether the brackets need moving forwards/backwards.
2. With the brackets aligned correctly, attach the fascia to the brackets over the top of the unit using the screws that come within in the kit.
3. Once all of the steps in '**Stereo Installation**' are complete, place the assembly into the dashboard and screw down using the pre-existing screws. Then reassemble the main fascia panel.

INTERFACE SET-UP

1. Take the interface and set the dipswitches accordingly (*note that these are default to off*):

| | ON (DOWN) | OFF (UP) |
|-------------|---------------------------------|---|
| DIPSWITCH 1 | Pioneer head units | All other head units (Default) |
| DIPSWITCH 2 | Reverse Camera PAL | Reverse Camera NTSC (Default) |
| DIPSWITCH 3 | Reset factory settings (switch) | Reset factory settings (Default) |
| DIPSWITCH 4 | Not Used | Not Used |

2. Take the 14-way connector on the vehicle interface harness and plug this into the relevant connection on the side of the interface.
3. Take the 12-way connector of the stereo patch lead and plug this into the relevant connection on the side of the interface. Then take the 3.5mm jack and attach this to the HEIGH10® unit.
4. Attach the 4-way camera extension harness to the interface.
5. Attach the antenna adapter to the vehicles pre-existing connection and the back of new HEIGH10® unit.
6. Attach the USB retention lead in between the vehicle pre-existing USB connector and the HEIGH10® unit.
7. Connect the male yellow RCA to the 'reverse camera input' on the back of the new stereo.
8. Connect the aftermarket reverse camera (if required) to the female yellow RCA on the camera extension harness.

Note: ensure the 'Camera Connected' option in the 'Preferences' menu is set to 'Yes' for the camera to function correctly.

9. Attach the additional wiring on the harness to the back of the stereo:
Pink - Speed Pulse **Green** - Park Brake **Purple** - Reverse
10. When all the above wires (and any additional accessories) have been connected, finally make the power connections between the stereo and the vehicles pre-existing connector.

For a full connection breakdown of the HEIGH10® unit, see the "**Installation Manual**" that comes with the unit.

CTSAD006.2

CAN-Bus Steering wheel control interface for Audi vehicles with Concert, Chorus or Symphony original stereos and Quadlock connectors. Retains OEM phone buttons and BOSE amplified systems

WIRING COLOUR CODES

| | | | |
|--------------|-----------------------|--------------|---------------|
| Purple | Right Rear Speaker + | Yellow | Permanent 12V |
| Purple/Black | Right Rear Speaker - | Black | Ground |
| Green | Left Rear Speaker + | Red | Ignition 12V |
| Green/Black | Left Rear Speaker - | Orange | Illumination |
| Grey | Right Front Speaker + | Green | Park Brake |
| Grey/Black | Right Front Speaker - | Pink | Speed Pulse |
| White | Left Front Speaker + | Purple/White | Reverse Gear |
| White/Black | Left Front Speaker - | Blue | Amp Remote |
| | | Blue/Black | Remote Output |

PRIOR TO INSTALLATION

*Read the manual prior to installation. Technical knowledge is necessary for installation. The place of installation must be free of moisture and away from heat sources. Please ensure that the correct tools are using during the installation to avoid damage to the vehicle or product. **Connects2 can not be held responsible for the installation of this product.***

FITTING GUIDE

1. Remove and disconnect the original head unit.
2. Connect the 12 way molex connector of the head unit patch lead (supplied separately) to the interface.

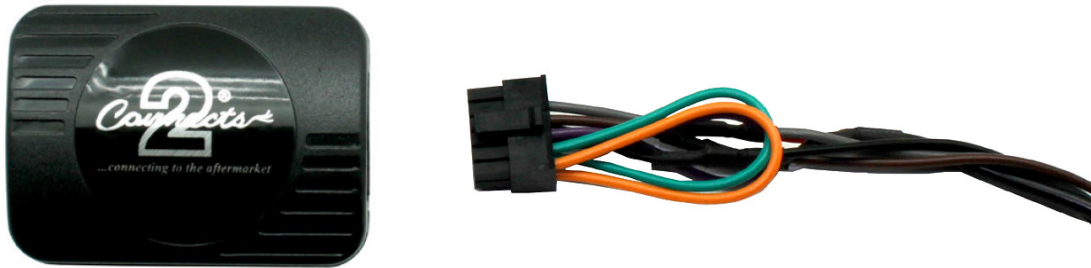

3. Connect the opposite end of head unit patch lead to the head unit steering wheel control input on the back of the aftermarket head unit.

NB: This may be a 3.5mm jack plug or a wire input depending upon the head unit brand being fitted. Please see the head unit installation manual for further information on where to connect.

Important: This step must be completed before connecting power to the interface. Failure to so do may result in no steering wheel control function.



4. Connect the 14 way molex connector to the interface



5. Connect the male power/speaker ISO harness to the female power/speaker ISO harness from the aftermarket head unit. For aftermarket head units without an ISO connector, please refer to "Wiring Colour Codes" on Pg. 2.

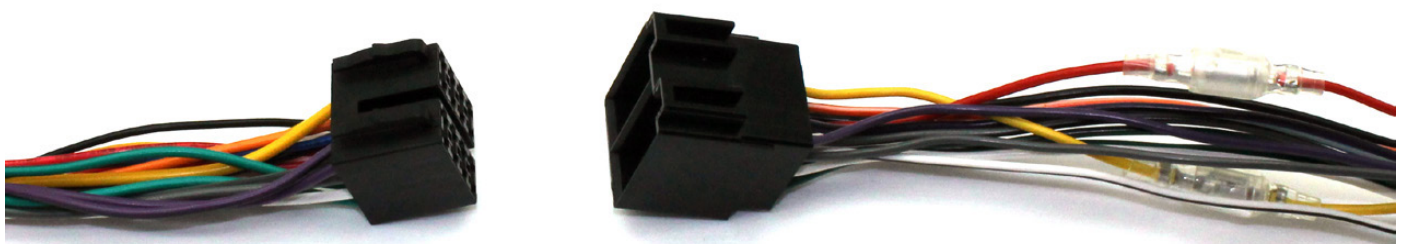

FITTING GUIDE

6. Connect the amp retention interface to the loom via the molex connector

7. Connect the female vehicle specific connectors on the harness to the male vehicle connector from the vehicle. Test head unit for correct operation.

STEERING WHEEL CONTROL FUNCTIONALITY

| Original Button | Function |
|------------------------|-----------------------|
| Up Arrow | Track + |
| Down Arrow | Track - |
| Volume + | Volume + |
| Volume - | Volume - |
| Mute | Mute |
| Speech | Pick Up (Short Press) |
| Speech | Hang Up (Long Press) |

TECHNICAL ASSISTANCE

For further help or assistance, please contact and fill out a support ticket with full details of your issue via : **uktechnical@aampglobal.com**

For general enquires, contact us at:

Phone: **01384 958 500**

E-Mail: **stinger.eu@aampglobal.com**

Mon - Fri 9am - 5.30pm GMT

If you would like to download a digital copy of this manual, or any other product, then please visit the **www.Stinger-Electronics-EU.com** website.

This manual is considered correct at the time of printing but is subject to change. For the latest manuals & updates, refer to our website.

Copyright 2023 by Stinger.

AGREEMENT: End user agrees to use this product in compliance with the instructions and terms of use and with all laws. STINGER provides instructions and safety warnings with respect to this product and disclaims all liability for any use not in conjunction with those instructions or other misuse of its product. If you do not agree, please discontinue use and contact STINGER. This product is intended for off-road use and passenger use only.